

## 12 Solid Reasons to Choose Hoffman Specialty

- Durable 3/16" steel receiver designed to meet government requirements.
- Inlet, vent and overflow receiver openings.
- Double pole adjustable float switch standard on simplex units.
- Durable float actuated mechanical alternator. Standard on the WCSD duplex unit.
- Close-coupled pump design.
- Quick, compact installation.
- Bronze-fitted centrifugal pump.
- Quiet, ball-bearing-type motor with dual voltage and thermal overload protection.
- Mechanical seal construction.
- Stainless steel shaft.
- Renewable bronze wearing ring.
- Factory wired and tested pump and motor assembly.

## Steel Receiver



**3-Simplex Units  
WCS 6,8 & 12-208**

**Duplex Units  
WCS D12-20B**

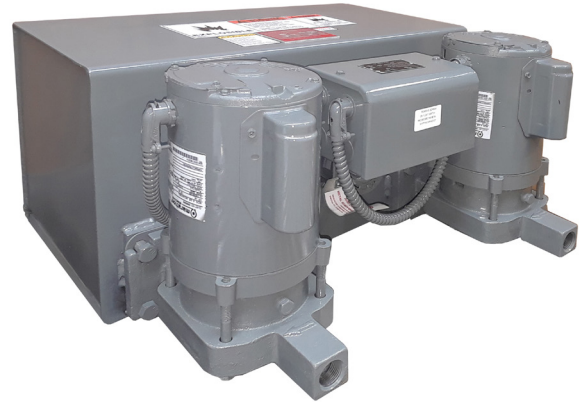

# Hoffman Specialty®

## Watchman® Series WCS™ Condensate Units

6,000, 8,000 AND 12,000 SQ. FT. EDR, SIMPLEX AND DUPLEX ARRANGEMENTS



# Hoffman Specialty Reliability and Dependable Quality. Mechanical Seal Pump Design.

**Mechanical seal design may be used in vacuum systems.**

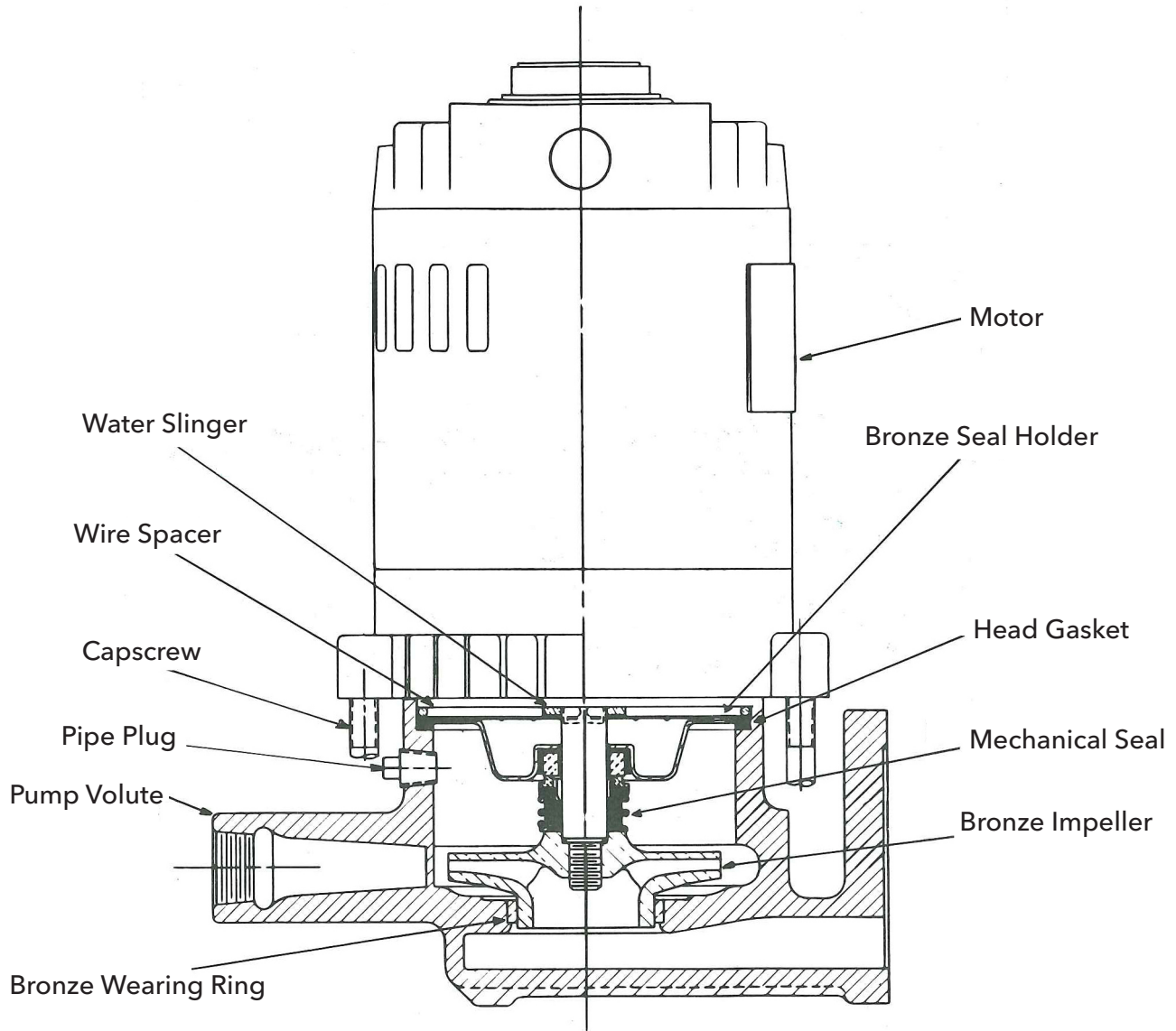

**Pump Construction Detail**

## Selection Table

System Sq. Ft. EDR	Type	Model No.	Shaft Seal	Capacity GPM	Discharge Pressure PSI	Receiver Capacity Gal.	Dripproof Motor
6,000	Single	WCS 6-20B	Mechanical	8	22	6	1/3 HP, 3500 RPM 1 Phase 115/230 volt 60 Hertz Wired for 115 Volts
8,000	Single	WCS 8-20B	Mechanical	12	21	9	
12,000	Single	WCS 12-20B	Mechanical	18	20	14	
12,000	Duplex	WCSD 12-20B	Mechanical	18	20	14	

All Watchman Units may be field converted to 230 volts.

### Motors Have Thermal Overload Protection.

**Optional Equipment: 2" "Y" Strainer for Receiver Inlet.  
2" Basket Strainer for Receiver Inlet.  
(Shipped Loose for Field Installation)**

**Ordering Instructions: Specify Catalog No.  
List Optional Equipment.**

## Suggested Specifications for Hoffman Watchman Series WCS Condensate Units

Furnish and install according to the plans and manufacturer's instructions the quantity of Hoffman Watchman Series WCS ( ) Simplex or ( ) Duplex Condensate Units as shown on the drawings and plans. Each unit shall consist of (1) steel receiver, (1) or (2) water pump(s) and float actuated pump switch as hereafter specified.

The condensate receiver shall be of 3/16" steel construction and shall be equipped with

a. Simplex Unit - (1) Externally adjustable 2-pole float switch.

or

b. Duplex Unit - (1) Externally adjustable mechanical alternator to automatically alternate operation of the two pumps and provide simultaneous operation of both pumps to deliver double capacity under peak conditions. Receiver shall be sized for 1 minute net storage based upon system return rate. Receiver shall have an inlet, vent and an overflow opening to provide a means of secondary venting.

The centrifugal pump(s) shall be flange mounted on the receiver. Pump(s) shall be close coupled vertical design, permanently aligned, bronze fitted and be

equipped with stainless steel shaft, enclosed bronze impeller, renewable bronze wear ring and mechanical shaft seal. Each pump shall be close coupled to a vertical dripproof motor. Motor(s) shall be 1/3 HP, 3500 RPM, single phase, 115/230 volt; factory wired for 115 volts; field convertible to 230 volts. Motor shall have internal thermal overload protection. Pump(s) shall be so constructed to permit access to the impeller and other interior parts without breaking the discharge pipe connections. Pump capacity shall be 8, 12 or 18 gpm at a minimum of 20 psi discharge pressure.

Each unit shall be factory tested. The manufacturer shall furnish complete elementary piping diagrams and installation and operation instructions.

Unit shall be a Hoffman Series WCS as manufactured by Xylem Bell & Gossett, Morton Grove, IL.

Model WCS 6-20B, WCS 8-20B, WCS 12-20B or WCSD 12-20B.

# Typical Installation

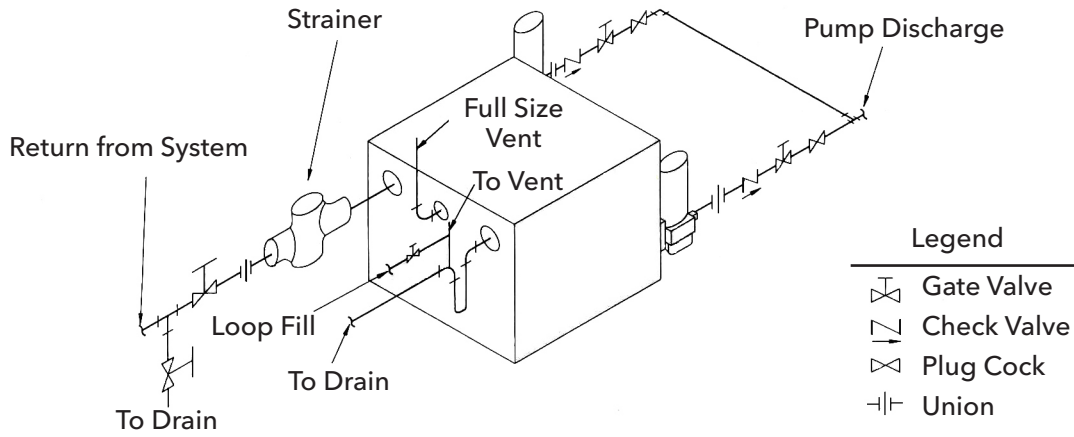

**IDPD45**

## Roughing-In Dimensions

(All dimensions in Inches)

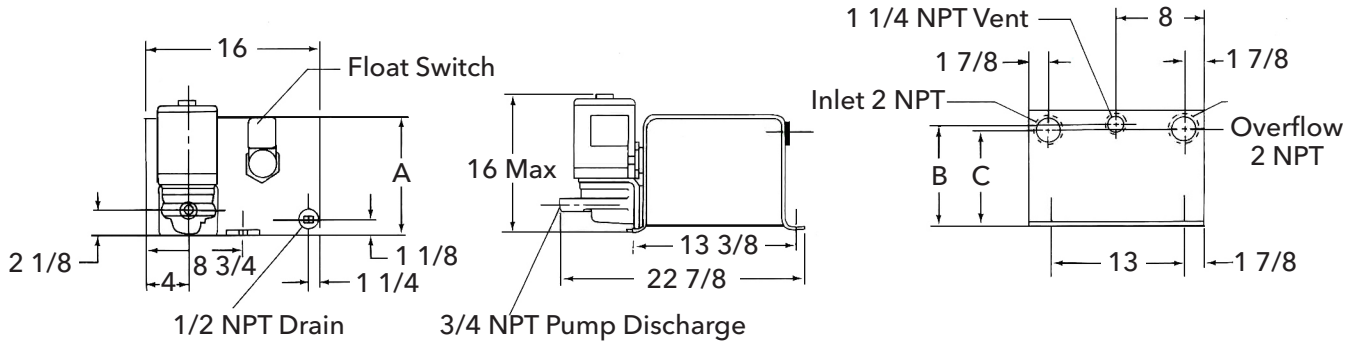

EDR	Style	Rec. Cap.	A	B	C
6,000	Single	6	8 9/16	7 1/16	6 11/16
8,000	Single	9	10 7/8	9 3/8	9

**6,000 & 8,000 Sq. Ft. EDR Units**  
**2DCC18**

## Roughing-In Dimensions

(All dimensions in Inches)

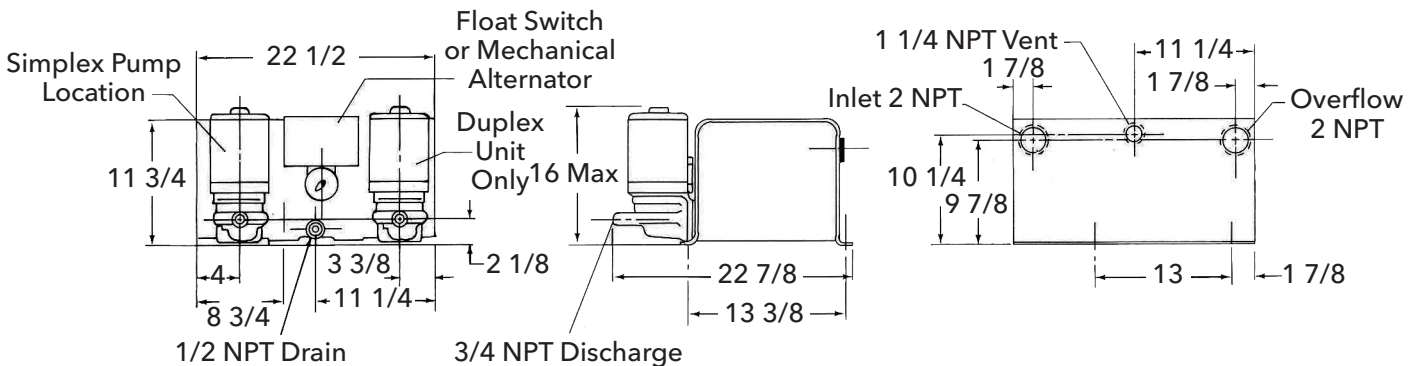

**12,000 Sq. Ft. EDR Simplex & Duplex Units**  
**2DCC19**



Xylem Inc.  
8200 N. Austin Avenue  
Morton Grove, Illinois 60053  
Phone: (847) 966-3700  
Fax: (847) 965-8379  
www.bellgossett.com